

The Importance of Switching

A Tutorial

by Jeffrey Lum, ASCOR

Switching probably is the most overlooked and undervalued part of a system design. Great attention is spent selecting the measurement and stimulus instruments. But more often than not, the chosen switching does not complement the instruments. It doesn't matter how accurate the instruments are if the signals pass through a poor switch design to get to them.

Engineers are familiar with test instruments because they have used them during their school years and at work testing products or debugging new designs. So it's easy for them to select instruments for an automated test system. Unfortunately, switching often is overlooked.

Choosing switches is more difficult because people often have little experience in test-system design. They are accustomed to moving test probes by hand, carefully connecting the probes and ground clips to the unit under test (UUT). A good designer should select the switching that best emulates what the engineer would have done when connecting instruments manually.

There are many types of switching: power, signal, coaxial, RF or microwave, and optical. Even within these categories, differences exist. Common in nonoptical relay terminology are voltage rating, switching current, current rating, and power rating.

- **Maximum Switching Voltage:** the maximum voltage rating of the relay when switched. The AC and DC voltage ratings are not always the same, so use caution. This rating applies during the time the relay is closing because the full voltage is across the open contacts. Once the relay

is closed, the voltage rating does not apply.

- **Maximum Switching Current:** the current during the time the relay is closing or opening. Exceeding these ratings will damage the contacts or even weld them.

- **Maximum Switching Current:** the rating of the contact for continuous current.

- **Power Rating:** the power rating of the contact at the time the contacts are opening or closing. This is specified in volt-amperes (VA) for AC voltage and current or watts for DC voltage and current. Power is the product of the voltage and current being switched. It must not exceed the power rating of the contact. Please note that the maximum power rating is not the product of the maximum voltage and maximum current.

Power Switches

Power switches generally are considered relays or switches rated greater than 60 W and at least 2 A. Typically, 2-A rated power switching uses printed-circuit traces instead of wires to carry the current.

Use caution when selecting the power switch. Look at the source as well as the load. Picking a switch that only will cover the load may lead to serious damage if the power-source capacity is much greater than the switch-current capacity or even the traces on the printed circuit board (PCB). The load that is being supplied with power may have a short in it. This would cause permanent damage to the PCB such as burnt traces and burnt or destroyed printed-circuit material.

Often engineers will provide shielded jackets to the power cables or even route the cables away from electrically noisy areas to get clean power to the UUT. Then they may insert power switches that do not provide shielding and wonder why they are seeing noise on the power lines.

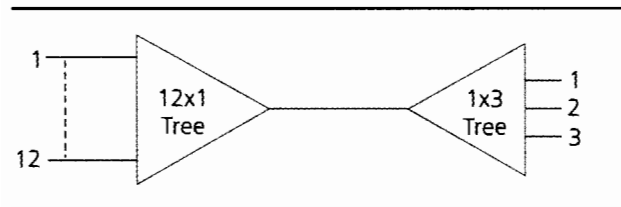

Figure 1.
A 12x1x3 Multiplexer

Designing suitable switching systems isn't as easy as it looks. Avoid some common pitfalls with advice from an industry leader experienced in several switching technologies.

Some power switches have built-in shielding that provides continuation of the shielded jacket in the power cable assembly. Not only are shielded power switches intended to continue the power cable shielding, but also to isolate noise that may be generated within the switch module so it does not affect the UUT. This noise may come from the power sources that control the switching or could be ground noise within the switch chassis or switch power supplies.

Signal Switching

Signal switching is perhaps the most common form of switching. Switches are available to connect a large variety of signals, both digital and analog. Signal switching is where most of the mistakes are made.

Test engineers often select high-performance signal sources or measurement instrumentation and then connect them to the UUT with the worst type of signal switching. Many engineers would claim that they are measuring low frequencies and they don't need the better switching. If so, why did they buy all of that expensive test equipment only to connect it to the UUT with bad switching?

A good example of such a case is a medical company that was building an electronic implant for the human body. It truly was low frequency and low power. The test equipment was all name-brand, high-performance instrumentation. The signal switching was rated at a 5-MHz bandwidth. This sounds good enough at first glance, yet nothing worked.

So much noise was seen on the oscilloscope that I could trigger on the reference clock from the VXI controller, measure the frequency of the switching power supply in the VXI chassis, and trigger on the 60 Hz from the AC power lines. All of these measurements were taken while connecting through the 5-MHz switch to the medical implant (UUT). The fundamental mistake was forgetting that connecting instrumentation to the UUT uses transmission-line technology.

In this case, the switch became an antenna and coupled all of the sources of signals in the grounds, power supplies, and air into the measurement path. Switching should be an extension of a transmission line, and it should behave as if the switch weren't there.

If the oscilloscope were manually connected to the UUT, the engineer would automatically connect the scope probe to the test point and the ground clip to a nearby ground on the UUT. If the engineer didn't connect that ground clip, a rectangular logic signal would have large aberrations or ringing. This poor-looking waveform is not because of the UUT or the oscilloscope but due to the poor transmission-line connection.

A contributing factor is an engineer's failure to appreciate the high frequencies that are part of a logic signal. Signals often are termed low frequency because of their fundamental frequency, and this value determines the performance of the test requirement. These signals are almost always digital with fast rise and fall times that equate to higher bandwidths:

$$t_r = 0.35/\text{bandwidth}$$

Engineers are disappointed that the test system is not as good as their bench setup. They fail to realize that they are using a several hundred megahertz oscilloscope with a 5-MHz switch stuck between it and the UUT. The weakest link is the switch. The ideal goal is to use a switch with performance that is so good that it doesn't affect the signal.

Coaxial switching is another class of signal switching that features a controlled impedance. It has higher bandwidth and much lower crosstalk. These switches are ideal for instruments such as oscilloscopes, counters, and signal sources that often have 50- Ω impedances.

Because of the high growth in telecom and video signals such as

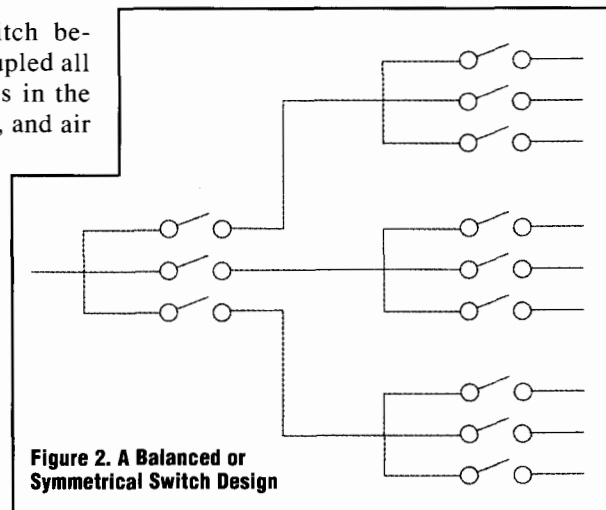

Figure 2. A Balanced or Symmetrical Switch Design

HDTV and broadband video, 75- Ω impedance also is becoming popular. For this technology, high-performance coaxial switching approaching microwave bandwidths is a necessity, but great care must be used when designing the cabling to coaxial switches. Poor shielding will result in bad performance.

Switch Configurations

Multiplexers

Switch multiplexers, commonly called trees, are a collection of switches or relays tied to a common point. They usually are used to connect a common piece of gear like a power supply to a number of points.

If only one switched path can be selected at a time, this is considered a one-of type switch or a scanner. A tree that can connect multiple paths at a time is considered any-of. A switch design that is any-of is useful for power supplies or sources, but they are very bad for measurement devices.

You do not want to switch multiple power sources together to the common voltmeter. The result is obvious. In VXI switch modules, some plug-&-play software allows the user to select the intent, whether it is a one-of or any-of configuration. This allows the same switch assembly to be used for either purpose.

Back-to-back multiplexers are multiple trees tied together to form a simple, larger-scale switch system.

For example, suppose you have 12 instruments that need to be connected to three points of a UUT. **Figure 1** shows a simple way to use a 12-to-one multiplexer, commonly call 12×1, and a one-to-three (1×3) multiplexer.

The commons are connected together to form a 12-to-one-to-three (12×1×3) multiplexer. The benefit usually is higher performance in terms of bandwidth. However, only one signal can pass between the instruments and the UUT because of the single common path.

Matrices

Switch matrices are rectangular arrays of switches or relays connected to form rows and columns of switches. Matrices are more versatile than multiplexers. Connecting a column to a row makes a path. For example, consider a matrix that has eight input rows and 16 output columns. It would be designated as an 8×16 matrix or 8×16.

Each column has eight relays to connect to the rows. Another way to state this is each row has 16 relays to connect to each of the 16 columns. This is very different than an 8×1×16 multiplexer. The matrix overcomes the disadvantage of the mux that has only one signal path available. The 8×16 matrix can have up to eight separate, simultaneous paths.

To make an 8×16 matrix using multiplexers requires the equivalent of eight 16×1 multiplexers and 16 1×8 multiplexers wired together. As in the multiplexers, when only one row can be assigned to a column, this is considered a one-of or blocking type of switch matrix. A matrix that can connect multiple rows to a column or vice versa is considered any-of or nonblocking.

Matrices are more complex and expensive than multiplexers because they need more relays. An 8×16 matrix requires a minimum of 48 relays compared to 24 relays for the 8×1×16 multiplexer. With matrices, bandwidth suffers because of the complexities associated with connecting multiple rows to multiple columns. This results in varying

bandwidths among the various paths of a matrix caused by the differences in transmission-line characteristics.

Matrix switching has stub lines, which cause reflections and degrade performance of the path. Some manufacturers describe the bandwidth of their matrices using typical as part of the specification. This can be very misleading.

The best approach is to state the worst-case path's bandwidth. Then at least you know that all the paths are equal to or better than the specification. A switch system with a typical bandwidth specification can have paths that are worse, but you don't know which ones they are.

Switch-System Performance

Simply joining two 10-MHz switch trees or matrices does not result in a larger 10-MHz switch system. A good rule of thumb is that the resulting rise time of a circuit is the square root of the sum of the squares of the rise times of the individual elements.

For example, if two switch matrices whose rise times are 1 ns are

joined together, it would result in a switch system whose rise time now is 1.4 ns. This can get more complicated depending on how the two matrices react to each other: reflections could occur due to stub lines between them and impedance mismatches.

Switch System for Instrumentation

The ideal switch has zero path resistance, infinite bandwidth, and zero crosstalk between channels. Of course, this isn't practical, but you can try to design a switch system that is balanced. This means that the switch design is symmetrical. The number of relays used to connect any given path between the instrumentation and the UUT is the same.

This technique maintains constant path resistance, and system losses become constant and predictable. Use worst-case bandwidth in your design consideration. Avoid cascaded designs because now you lose control of your design goals unless you know the resulting performance of cascading switch elements. **Figures 2 and 3** show examples of balanced and cascaded switching circuits, respectively.

Figure 4 is a simple example of a switch-system design that could be used for instrumentation. It consists of multiplexers and matrices and is segmented into low-frequency and high-frequency sections.

The low-frequency section is a matrix and a series of trees that connect a large number of UUT low-frequency points to the voltmeter or any other low-frequency instrumentation. The low-frequency trees (30-MHz bandwidth worst-case) are balanced trees, meaning that all inputs to the common point of the tree go through the same number of relays.

These trees are connected to the matrix (50-MHz bandwidth worst-case), and it too is a balanced design because the number of relays used for any connection from row to column is the same. The combined bandwidth is greater than 15 MHz,

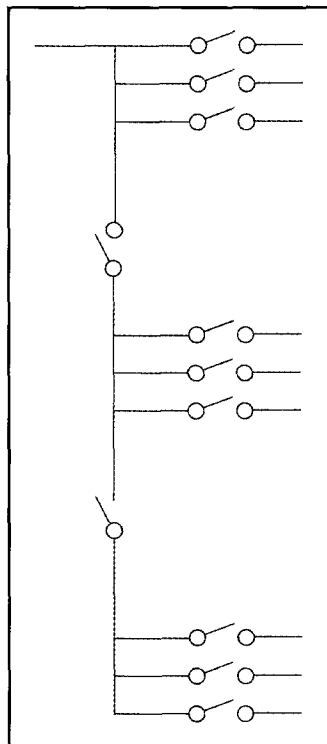

Figure 3.
A Cascaded Switch Design

which far exceeds the typical 1-MHz bandwidth of the voltmeter for true rms or AC measurements.

At the bottom of the diagram are high-frequency coaxial trees to switch high-performance UUT signals to the high-frequency instrumentation such as the oscilloscope and the counter. These are controlled-impedance switches with high bandwidths and low crosstalk. The cables are matched-impedance coaxial cables.

The 800-MHz star switch is a form of a switch tree that functions like an intermediate switch to route the various high-frequency trees to the oscilloscope or the counter. In fact, it is an isolation switch to maintain performance of the intended path and disconnects the other lines that would have resulted in stub lines.

A simple observation of this example demonstrates its versatility. The high-frequency signal path connects from a 350-MHz tree to an 800-MHz star switch to a 200-MHz high-frequency matrix to an isolation switch to a 50-MHz, low-frequency switch to reach a 1-MHz DMM. The bandwidth degradation due to this path is almost nil.

The path resistances are the same so the attenuation can be predicted. It is far better to have a few variations in resistance over a number of paths than design a switch system where every path uses a different number of relays and each path has a different bandwidth and attenuation factor. That is why a balanced switch design is important.

Conclusion

Switching in the instrumentation environment is not as simple as most people think. Since the switch system usually is placed between the UUT and the instruments, system performance will be dictated by the switch design unless its performance is far greater than that of the instruments. The ultimate success or failure of an ATE design depends on the proper connection of instrumen-

tation to the UUT and that, in turn, relies on the switching and transmission-line design.

If you need all 6.5 digits in a DMM measurement, then pick your switch system accordingly. Other-

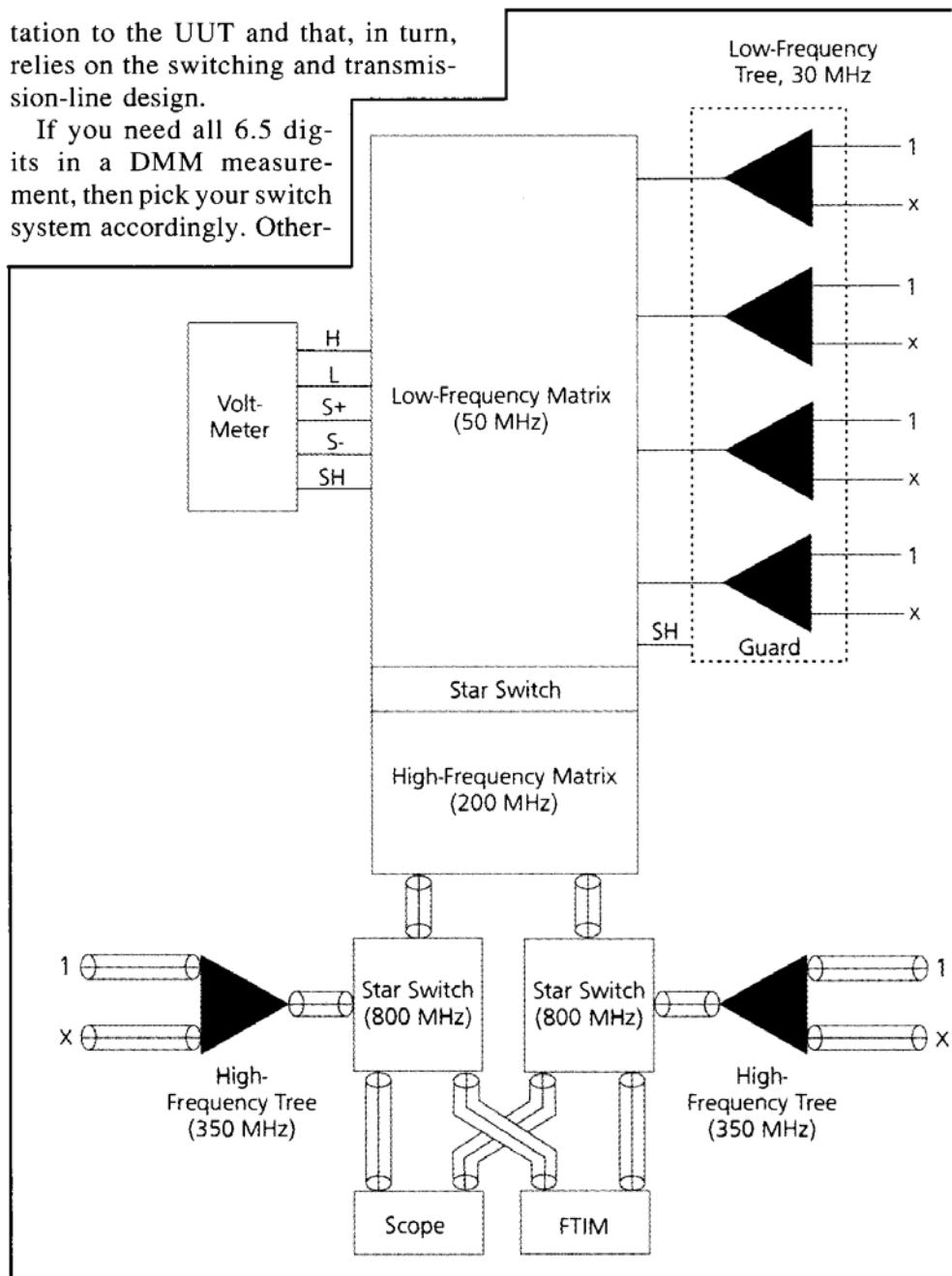

Figure 4. A System Switch Example

wise, buy a 3.5- or 4.5-digit meter and save money. If you choose an inadequate switch, the lower digits on the 6.5-digit meter will be meaningless because of bandwidth loss, jitter, or noise. The correct switch is as important or even more important than the instruments themselves.

About the Author

Jeffrey Lum, the president of ASCOR, founded the company in 1987, and in 1996, ASCOR merged with Gigatronics. Previously, he was the vice

president and co-founder of Autek Systems. In addition to holding several patents, Mr. Lum earned a B.S. in electrical engineering and has written several magazine articles.

EE



4650 Norris Canyon Road, San Ramon, CA 94583
800. 726. GIGA (4442)
inquiries@gigatronics.com
www.gigatronics.com